

# SR10

**SHANTUI**  
VALUE THAT WORKS

ROLLER  
SERIES

ENGINE MODEL	WP4G110E220
GROSS POWER	82kW @ 2200rpm
OPERATING WEIGHT	10000kg

LET'S MAKE  
CONSTRUCTION EASIER





# SR10 TECHNICAL PARAMETERS

## ROLLER SERIES

**SHANTUI**  
VALUE THAT WORKS

ENGINE	SR10	SR10P
Model	Weichai WP4G110E220	
Number of Cylinders	4	
Type	4-cycle, Direct Injection, Water-cooled	
Aspiration	Turbocharged	
Bore x Stroke	105*130mm	
Displacement	4L	
Gross Power	82kW @ 2200rpm	
Max. Torque	560N.m @ 1400~1600rpm	
Rated Fuel Consumption	200g/kW.h	
Air Cleaner	2-stage, Dry Type	
POWER TRAIN	SR10	SR10P
Type	Hydrostatic, All-wheel Drive	
Driving Pump	Mechanical Control, Variable Piston Pump 75ml/r	
Axle Drive	Variable Piston Motor, 105ml/r	
Drum Drive	Constant Piston Motor, 55ml/r	
Hydraulic Relief Pressure	35MPa	
Tire	23.1-26-8PR/20.5-25-16PR	
Max. Grade Ability	48%	
Forward, I, II	0~5.3km/h, 0~9.9km/h	
Reverse, I, II	0~5.3km/h, 0~9.9km/h	
STEERING	SR10	SR10P
Type	Hydraulic Power, Articulated Steering	
Hydraulic Relief Pressure	14MPa	
Steering Angle	±35°	
Oscillating Angle	±12°	
Min. Turning Radius	5880mm	
BRAKES	SR10	SR10P
Service Brake	Hydraulic Inertia Brake	
Parking Brake	Multi-disc Brake, Hydraulic Control	
Emergency Brake	Hydraulic Inertia Brake & Multi-disc Brake	
DRUM	SR10	SR10P
Width	2130mm	2130mm
Diameter	1500mm	1650mm
Drum Shell Thickness	20mm	20mm
Number of Pad Feet	-	132
Height of Pad Feet	-	95mm
VIBRATION	SR10	SR10P
Type	Hydrostatic, Electric Control	
Vibration Pump	Variable Piston Pump, 55ml/r	
Vibration Motor	Constant Piston Motor, 55ml/r	
Hydraulic Relief Pressure	30MPa	
Frequency, Low	30Hz	29Hz
Frequency, High	35Hz	34Hz
Amplitude, High	2mm	1.7mm
Amplitude, Low	1mm	0.85mm
Centrifugal Force, Maximum	270kN	270kN
Centrifugal Force, Minimum	180kN	180kN

CAPACITIES	SR10	SR10P
Fuel Tank	180L	
Hydraulic Oil Tank	80L	
Engine Coolant	25L	
Engine Crank Case	16L	
ELECTRICAL SYSTEM	SR10	SR10P
Battery	2x12V, 105Ah	
Alternator	28V, 70A	
Starter Motor	24V, 6kW	
WEIGHT	SR10	SR10P
Operating Weight	10000kg	11000kg
Axle Load, Drum	6000kg	7000kg
Axle Load, Wheel	4000kg	4000kg
Static Linear Load(at Drum)	281N/cm	382N/cm

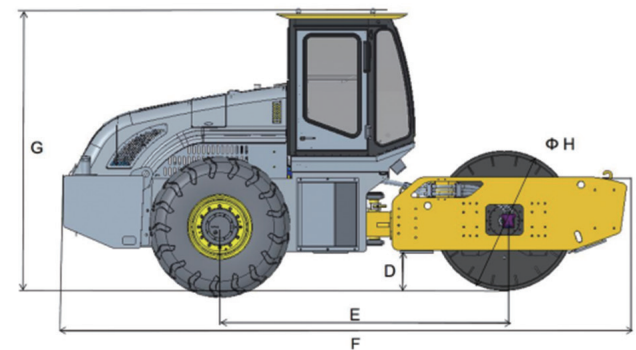
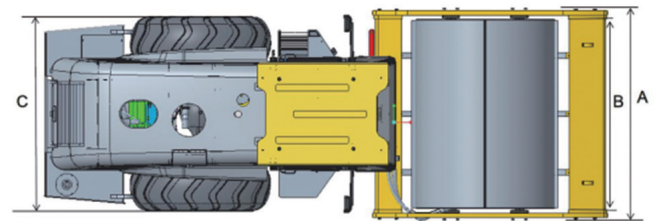

DIMENSIONS	CAB	CANOPY
A	2313mm	2313mm
B	2310mm	2310mm
C	2181mm	2181mm
D	442mm	442mm
E	3172mm	3172mm
F	5909mm	5909mm
G	3225mm	3225mm
H	1500mm	1500mm